



## SERVICE LETTER No. L 148

### MAINTENANCE ALERT

- DATE:** April 30, 2024
- TO:** All operators of ZLIN airplanes
- MODELS AFFECTED:** All Z 242 L aircraft
- SUBJECT:** IN-SERVICE SAFETY EVENT REPORTING
- TIME OF COMPLIANCE:** Immediately after receipt of this letter
- PURPOSE:** As a reaction to registering the fault of a pin of the main hinge of the wing, the manufacturer of aircraft, ZLIN AERO a.s., prescribes a number of immediate measures to all operators as a part of immediate reaction and demands immediate execution of the following actions in order to secure the safety of flight operations of the aircraft:
1. The basic technical lifetime of pins of the main hinge of the wing of the aforementioned aircraft is set to **1500 flight hours** or **200 flights hours** in AEROBATIC category. (whichever comes first and/or if a shorter time is not determined by the evaluation of the data from the AMU 1 accelerometer).  
*At reaching the lifetime limit of the pins, they need to be replaced by new pins immediately.*  
*In case of removing the vertical pin, drawing number Z42.2181 (Ø20 h6), and/or horizontal pin, drawing number Z42.2191-00.00 (Ø20 h6) – see Picture 1, 2) for any reason, it is necessary to always install completely new pins of the same dimension.*  
*Re-use of the originally installed pins after their removal is forbidden and they always need to be taken out from operation, which must be properly documented.*
  2. Conduct an immediate inspection of application of prescribed torque moment for tightening the nuts of pins of the hinge of the wings in all operator's aircraft. It is obligatory to proceed according to the relevant technical documentation.  
Record a written report of the conducted inspection into the aircraft documentation.



For tightening nuts M10 – see Picture 1, item 3, a torque wrench must be used at all times to meet the requirements of the prescribed tightening torque (23-27 Nm – see Maintenance Manual part 2, chapter 7.5).

**Tightening of nuts without using the torque wrench is forbidden.**

**NOTE:**

Always use only tools prescribed by the manufacturer for pin removal (drawer L242.9510-00.00).

**It is forbidden to use tools not approved by the manufacturer for pin removal.**

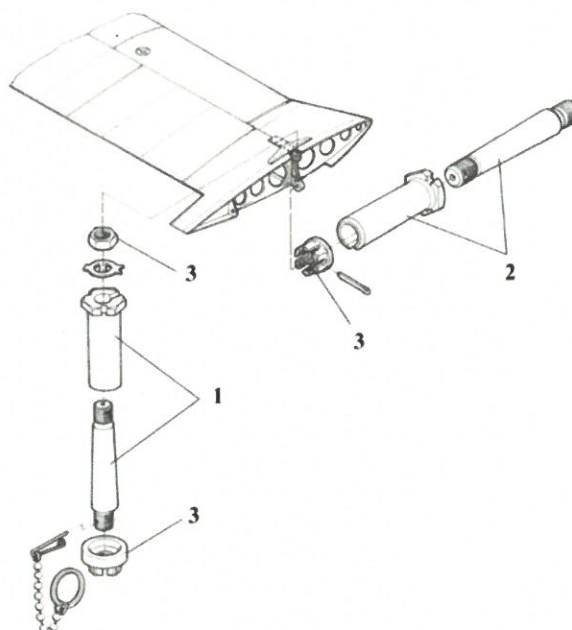

Fig. No. 1

**NOTE:**

The reporting of accidents and incidents is vital to ZLIN's compliance with 21.A.3A "Reporting of failures, malfunctions, and defects."

**CAUTION:**

Failure to follow the procedures outlined in this letter will result in the operator being held fully responsible for the possible occurrence of incident, accident or crash.

Elaborated by:

  
.....

**Lubomír Januška**

Head of Documentation and Normalization Dept.